

**TOOLS REQUIRED**

- 1. FLAT HEAD SCREWDRIVER OR 1/8" PUNCH (STEP 1)
- 2. IP27 TORX DRIVER (STEP 2)
- 3. 7/32" WRENCH (STEP 4)
- 4. LONG 3/32" HEX KEY (STEP 5)
- 5. 5mm or 3/16" PUNCH (STEP 7)

**STEPS 1-3 SHOW HOW TO REMOVE YOUR OLD GEN 2 HANDGUARD.**

**STEPS 4-8 SHOW HOW TO REVERSE YOUR CHARGING HANDLE & BUMPER FOR A LEFT HANDED SHOOTER.**

**STEP 1: USE FLAT HEAD SCREWDRIVER OR 1/8" PUNCH TO FIELD STRIP RECOIL SPRING ASSEMBLY & BOLT-CARRIER GROUP PER MANUAL**

**STEP 2: USE IP27 TORX DRIVER TO REMOVE TWO HANDGUARD SCREWS & SPLIT WASHER**

**STEP 3: SLIDE OLD HANDGUARD ASSEMBLY FORWARD OFF OF UPPER RECEIVER ASSEMBLY**

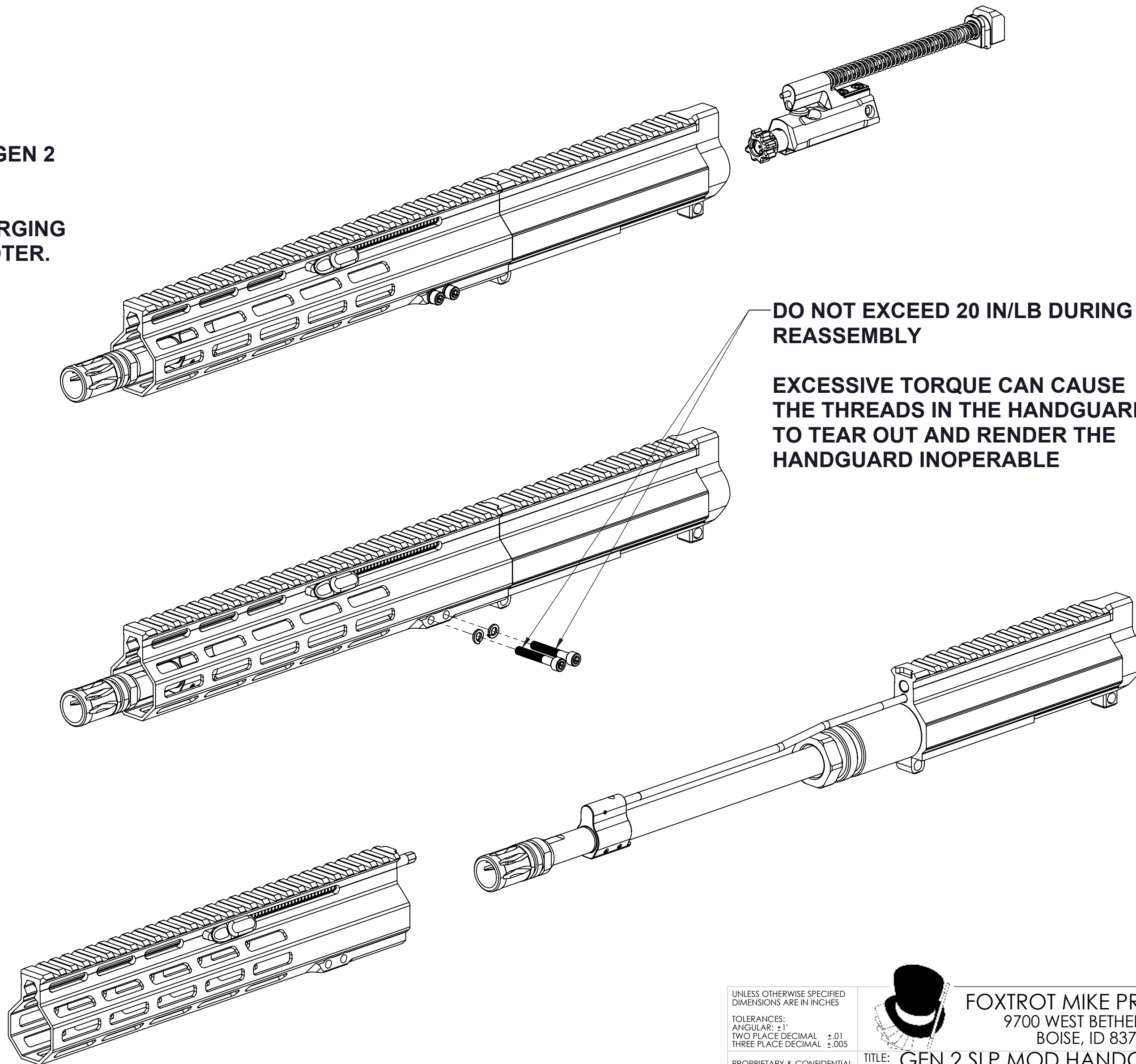

REV.	DESCRIPTION	DATE	APPROVED
A	PRELIMINARY RELEASE	5/30/24	A. TROUT

UNLESS OTHERWISE SPECIFIED  
DIMENSIONS ARE IN INCHES

TOLERANCES:  
ANGULAR: ±1°  
TWO PLACE DECIMAL ±.01  
THREE PLACE DECIMAL ±.005

PROPRIETARY & CONFIDENTIAL  
THE INFORMATION CONTAINED IN  
THIS DRAWING IS THE SOLE  
PROPERTY OF FOXTROT MIKE  
PRODUCTS. ANY REPRODUCTION IN  
PART OR AS A WHOLE WITHOUT THE  
WRITTEN PERMISSION OF FOXTROT  
MIKE PRODUCTS IS PROHIBITED.



**FOXTROT MIKE PRODUCTS**  
9700 WEST BETHEL COURT  
BOISE, ID 83709

**TITLE: GEN 2 SLP MOD HANDGUARD  
INSTALLATION INSTRUCTIONS**

SIZE	DWG. NO.	REV
C	2405016	A

DO NOT SCALE DRAWING	SCALE: 1:2	WEIGHT:	SHEET 1 OF 2
----------------------	------------	---------	--------------

REV.	DESCRIPTION	DATE	APPROVED
A	PRELIMINARY RELEASE	5/30/24	A. TROUT

**STEP 4: USE 7/32" WRENCH TO LOOSEN CHARGING HANDLE ROD. PULL ROD AND SPRING OUT FROM REAR OF HANDGUARD.**

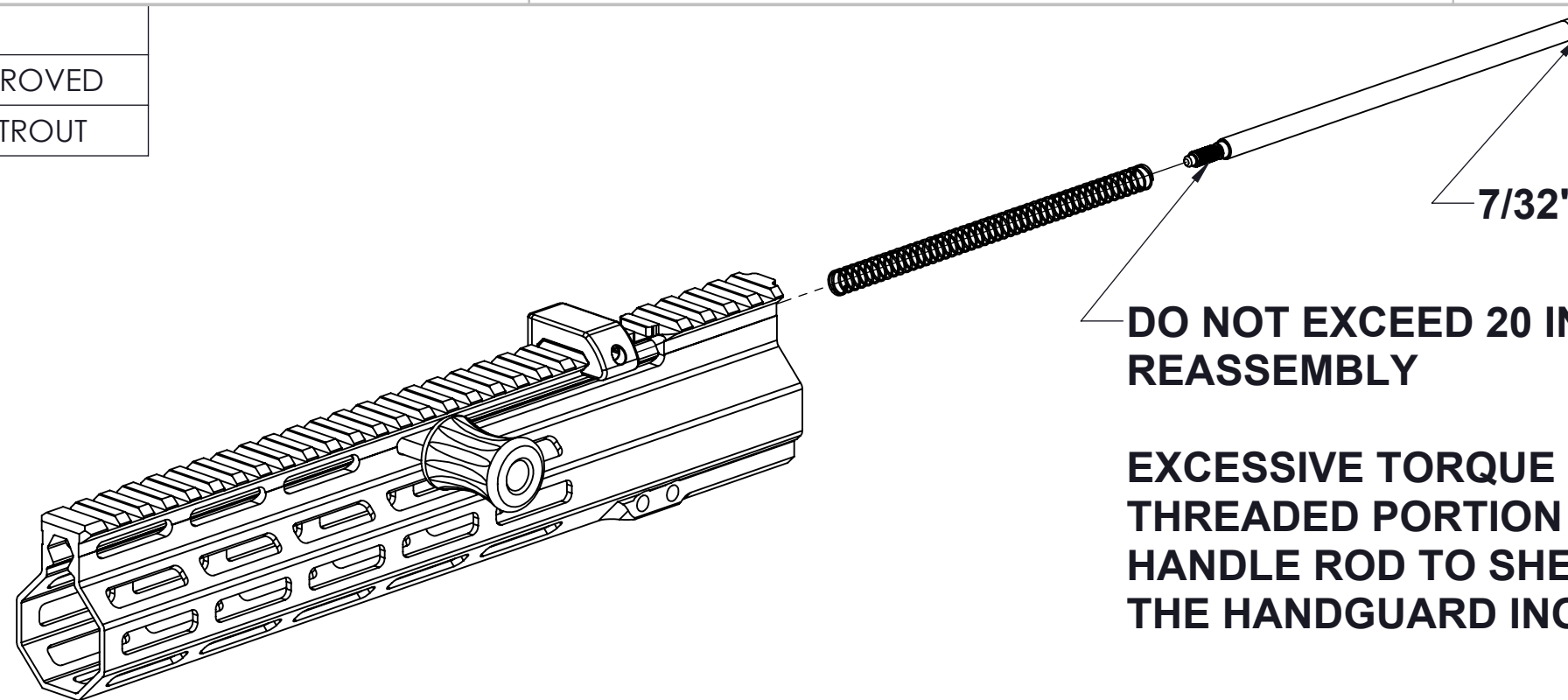

**STEP 5: USE LONG 3/32" HEX KEY TO REMOVE TWO #10-32 SET SCREWS FROM THE FRONT OF THE CHARGING HANDLE TROLLEY**

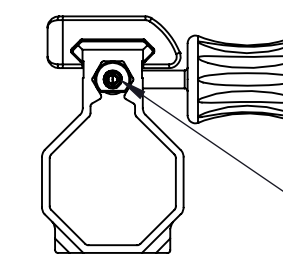
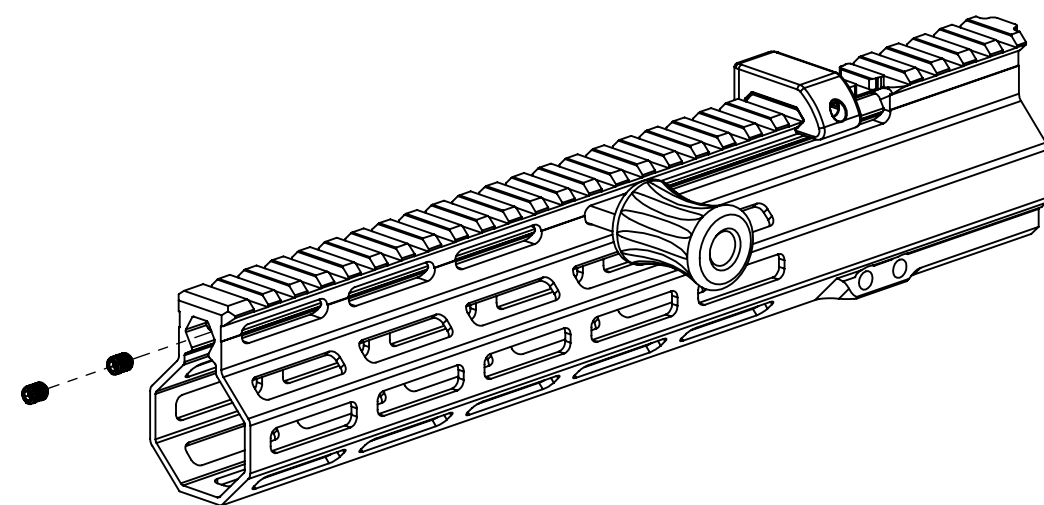

**SET SCREWS ARE LOCATED HERE IN THE FRONT OF THE CHARGING HANDLE TROLLEY**

**STEP 6: PULL OUT THE CHARGING HANDLE AND SLIDE THE CHARGING HANDLE TROLLEY OUT OF THE HANDGUARD HEX CHANNEL**

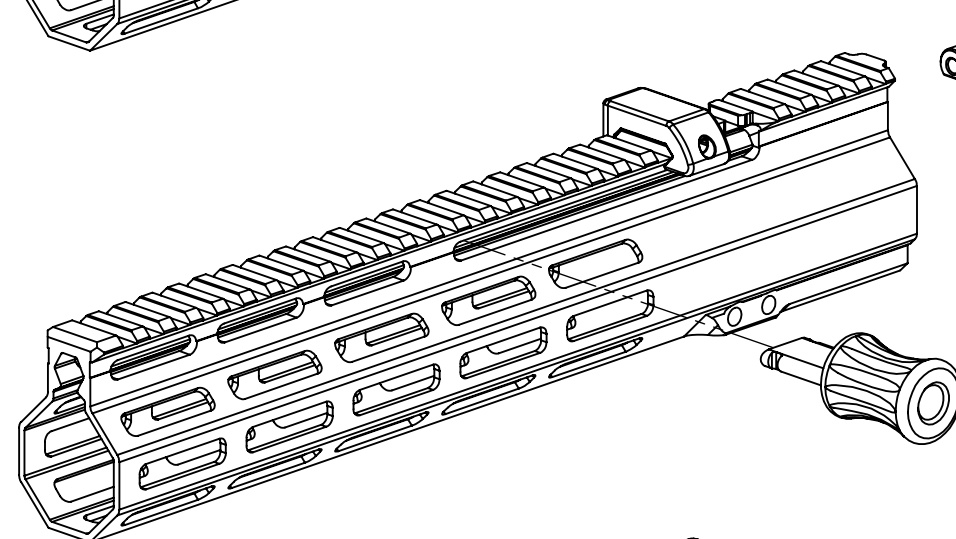

**ENSURE FLAT SIDE OF CHARGING HANDLE TROLLEY IS FACING DOWN WHEN INSTALLED**

**REASSEMBLY NOTES:**

- 1. REASSEMBLE IN REVERSE ORDER**
- 2. CLEAN ALL THREADS WITH ACETONE OR SIMILAR SOLVENT**
- 3. USE BLUE LOCTITE 243 OR SIMILAR THREAD LOCKER ON THREADS**
- 4. TIGHTEN ALL THREADS TO 15-20 IN/LBS**
- 5. LUBE THE EXTERIOR OF THE CHARGING HANDLE ROD & TROLLEY WITH GREASE BEFORE INSTALLING HANDGUARD ON UPPER RECEIVER ASSEMBLY**

**STEP 7: USE 5mm OR 3/16" PUNCH TO DRIVE OUT BUMPER SPRING PIN. THEN SLIDE BUMPER REARWARD UNTIL IT CAN BE LIFTED OFF THE PICATINNY RAIL.**

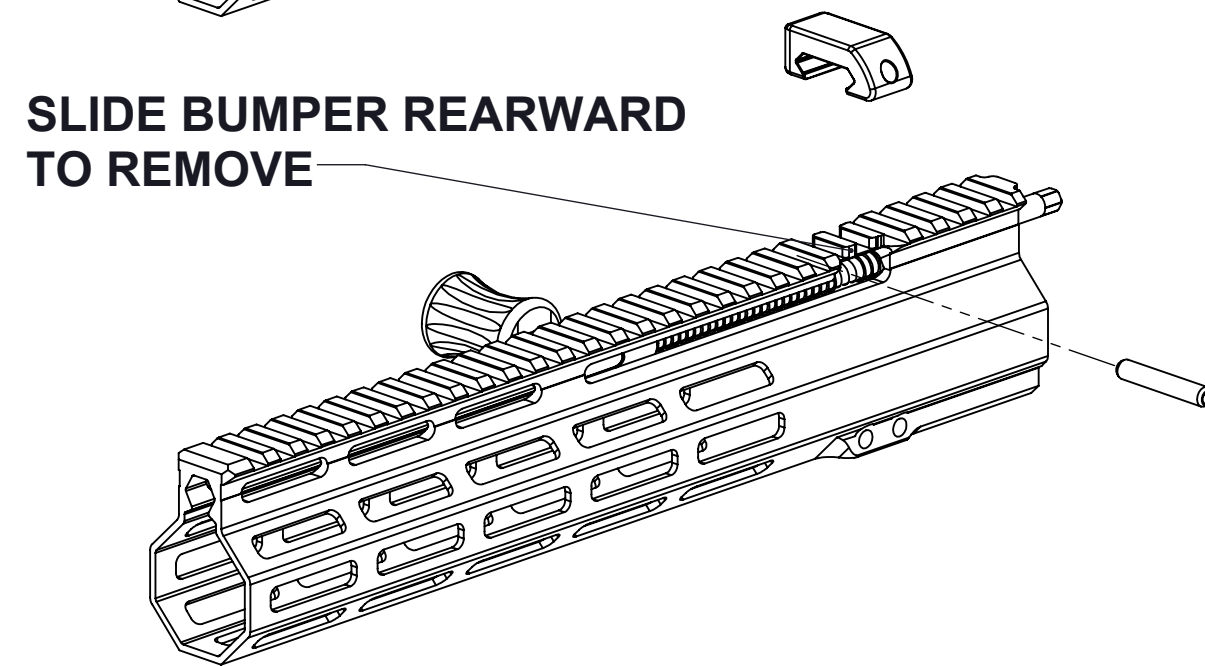

**SLIDE BUMPER REARWARD TO REMOVE**

**STEP 8: REVERSE BUMPER DIRECTION AND REINSTALL ON PICATINNY RAIL.**

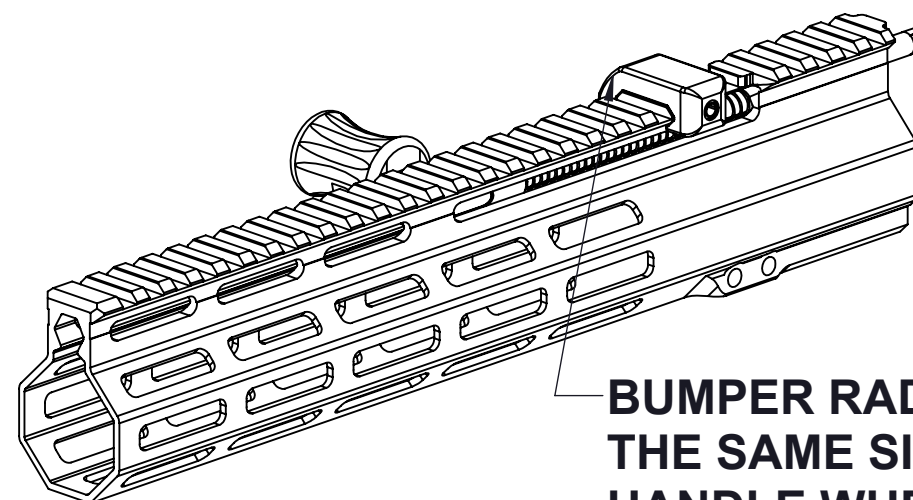

**BUMPER RADIUS SHOULD BE ON THE SAME SIDE AS THE CHARGING HANDLE WHEN INSTALLED**

UNLESS OTHERWISE SPECIFIED DIMENSIONS ARE IN INCHES  
 TOLERANCES:  
 ANGULAR: ±1°  
 TWO PLACE DECIMAL ±.01  
 THREE PLACE DECIMAL ±.005  
 PROPRIETARY & CONFIDENTIAL  
 THE INFORMATION CONTAINED IN THIS DRAWING IS THE SOLE PROPERTY OF FOXTROT MIKE PRODUCTS. ANY REPRODUCTION IN PART OR AS A WHOLE WITHOUT THE WRITTEN PERMISSION OF FOXTROT MIKE PRODUCTS IS PROHIBITED.  
 DO NOT SCALE DRAWING



**FOXTROT MIKE PRODUCTS**  
 9700 WEST BETHEL COURT  
 BOISE, ID 83709

**TITLE: GEN 2 SLP MOD HANDGUARD INSTALLATION INSTRUCTIONS**

SIZE DWG. NO. **C 2405016**

REV **A**

SCALE: 1:2

WEIGHT:

SHEET 2 OF 2