



# **MIKE-102 GEN 2 QUICK START GUIDE**

**READ THESE INSTRUCTIONS AND  
WARNINGS IN THIS GUIDE CAREFULLY  
BEFORE USING THIS PRODUCT**

**FAILURE TO FOLLOW THESE GUIDELINES MAY  
RESULT IN DAMAGE TO YOUR PRODUCT AND  
VOID THE LIFETIME WARRANTY**

**© 2023 Foxtrot Mike Products, Inc.**

**[WWW.FM-PRODUCTS.COM](http://WWW.FM-PRODUCTS.COM)**

REV C 9/23

# TABLE OF CONTENTS

	Page
Warnings .....	2
A Message from the CEO .....	3
Warranty Statement .....	4
The Rules of Safe Firearm Handling .....	5
Ammunition Selection .....	6
Magazine Selection .....	8
Operational Controls .....	9
- Safety .....	9
- Fire Control (Trigger System) .....	9
- Charging Handle .....	10
- Magazine Catch .....	11
- Bolt Stop .....	11
- Ejection Port Cover .....	11
Loading & Reloading .....	12
Clearing Malfunctions .....	14
Field Stripping .....	15
- Extractor Removal .....	17
Break-In & Maintenance .....	19
Troubleshooting Tips .....	21
Accessorizing your MIKE-102 Gen 2 .....	22
- Proprietary Parts .....	22
- 4-Position Charging Handle .....	22
- Gen 2 Handguard .....	23
- Sights & Optics .....	24
- Muzzle Devices .....	24
- Stock Adapter .....	24
- Fire Control (Trigger System).....	25
- Bolt Carrier Assembly .....	26
- Lower Receiver .....	27
A Note on Aftermarket Accessories .....	27
State-By-State Warnings .....	28

**IF YOU ARE HAVING A PERSISTENT MALFUNCTION WITH YOUR MIKE-102 GEN 2 PLEASE GO TO “TROUBLESHOOTING TIPS” ON PAGE 21 AND FOLLOW THOSE STEPS.**

# WARNINGS

**WARNING:** IF THIS FIREARM IS IMPROPERLY HANDLED, UNINTENTIONAL DISCHARGE COULD RESULT AND COULD CAUSE INJURY, DEATH, AND/OR DAMAGE TO PROPERTY.

**WARNING:** BEFORE USING THIS FIREARM, READ, UNDERSTAND AND FOLLOW THESE INSTRUCTIONS. THIS FIREARM SHOULD BE CONSIDERED LOADED AND READY TO FIRE UNTIL YOU REMOVE THE MAGAZINE AND VERIFY THAT THE CHAMBER IS UNLOADED.

If there is anything you do not understand, get assistance from a qualified gunsmith in the safe handling and maintenance of firearms.

This instruction manual should always accompany this firearm and be transferred with it upon change of ownership, or when the firearm is loaned or presented to another person.

As a firearm owner, it is your job to know the local, state and federal laws regarding firearms ownership. The warnings listed in this manual are not inclusive of all states and are subject to change without notice. Please check with your local authorities for current laws and regulations in your locality.

## **WARNING: LEAD EXPOSURE**

Discharging firearms in a poorly ventilated area, or handling or cleaning firearms and ammunition can result in an exposure to lead and other harmful substances known in the State of California to cause birth defects, reproductive harm, and other serious physical injury.

Adequate ventilation must be maintained at all times when handling, cleaning or firing firearms. Wash your hands thoroughly after exposure. The use of gloves, glasses and other protective gear during firearm cleaning is recommended.

# **A MESSAGE FROM THE CEO**

**Dear Customer,**

I want to personally thank you for purchasing one of our new MIKE-102 Gen 2 firearms.

When I started FM Products the motto we chose was:

**“Cutting edge is all we do.”**

We currently produce some of the most feature rich, simple and reliable 5.56 & 9mm AR-pattern firearms on the market. We could not have accomplished that without the support of our customers.

For the last couple years we have been producing and refining the MIKE-15 Gen 2 platform. Thought was put into every aspect of this firearm, and we chose to do things differently in order to offer the best possible product for our customers.

The success of the MIKE-15 Gen 2 lead us to developing the MIKE-102 Gen 2, based on consumer feedback at events like Kalash Bash & Red October.

Our philosophy is, we will always try to improve our products based on our consumers feedback.

Thank you for choosing to join us on this journey. We hope our attention to detail shows you how much we care about you as a customer.

**Paul Noonan**  
**CEO, Foxtrot Mike Products**

# **WARRANTY STATEMENT**

Foxtrot Mike Products is known for our lifetime warranty on all our products.

In the event that our customers have any of our products fail, FM Products will replace those parts at no cost to you.

Our lifetime warranty does not cover shipping the warranty items to us, however we will pay for return shipping the warranty items back to you.

Our lifetime warranty does not cover failures caused by ammunition, other manufacturers components, or negligence on the part of the shooter.

Please contact us at [info@FM-Products.com](mailto:info@FM-Products.com) for instructions on any warranty returns. FM Products answers customer service emails 7 days a week.

We appreciate you as a customer, and want you to be satisfied with your purchase.

FM Products strives to provide you with a quality firearm that will last a lifetime.

## **DISCLAIMER**

Foxtrot Mike Products expressly disclaims liability for incidental or consequential damages.

You, as the owner and operator of this firearm, are responsible for its safe and lawful use.

# **THE RULES OF SAFE FIREARMS HANDLING**

1. Always wear eye and ear protection when shooting.
2. Learn the mechanics and handling characteristics of the firearm before use.
3. Always keep your firearm's muzzle pointed in a safe direction.
4. Keep your finger off the trigger until you are ready and intending to shoot.
5. Be sure of your target and what is beyond it.
6. Use only quality ammunition of the correct caliber in your firearm.
7. Be sure that your firearm and ammunition are in good working condition.
8. Your firearm should be unloaded and properly stored when not in use.

# AMMUNITION SELECTION

**ALWAYS use high-quality, factory loaded ammunition.**

Reloading is a science and improperly loaded ammunition can be extremely dangerous. FM Products specifically disclaims responsibility for any damage or injury whatsoever occurring in connection with, or as a result of, the use of faulty, nonstandard, “remanufactured” handloaded (reloaded) ammunition, or cartridges other than those for which the firearm was originally chambered.\*\*

**FM Products strongly recommends using brass cased ammunition, however our firearms are designed to run steel cased ammunition.**

To reiterate, running steel cased ammunition will NOT void your warranty, however there are 2 ammunition related malfunctions that can appear when running steel cased ammunition that FM Products cannot prevent or warranty.

1) Steel cased ammunition generally uses harder primers, which can occasionally cause a malfunction when the firing pin strikes the primers sufficiently, and the round does not ignite. Clear the round from the weapon and discard. DO NOT attempt to re-chamber this round. The round will show a pronounced impact from the firing pin hitting the primer, but the round did not fire. This is an ammo related malfunction.

2) Steel cased ammunition is more likely to stick in a hot chamber than brass ammo. This can cause a “failure to extract”. We recommend removing the bolt and using a cleaning rod to tap out this stuck casing. Check your extractor for any damage before continuing. This is an ammo related malfunction.

## **AMMUNITION SELECTION, CONT'D**

**USING SILENCERS:** FM Products supports the use of silencers; we recommend using .223 Remington ammunition when shooting suppressed to reduce back pressure and bolt carrier velocity. We do not recommend using hot ammunition when you are running a suppressor.

**ALWAYS** function test any new ammunition before using in competition, for personal defense, or buying in bulk for leisure shooting.

**ALWAYS** use ammunition that complies with the industry performance standards established by the Sporting Arms and Ammunition Manufacturers' Institute, Inc. of the United States (SAAMI) or ammunition manufactured to military specifications.

**NEVER** use cartridges that are dirty, wet, corroded, bent, or damaged.

**NEVER** oil cartridges.

**NEVER** spray aerosol-type lubricants, preservatives, or cleaners directly onto cartridges or where excess spray may flow into contact with cartridges.

\*\* In the event a customer uses ammunition that is not recommended with our products, FM Products may choose to charge customers to repair or replace any damaged parts that caused damage to the firearm or parts.



# **MAGAZINE SELECTION**

**ALWAYS** use high quality AK-102 pattern 5.56x45mm magazines like **AC-Unity** and **Circle 10**.

Many feeding issues are the result of inferior, imported magazines.

Use a dry brush to clean your magazines after use in dusty or dirty environments.

**NEVER** use lubricants inside of magazines.

FM Products does **NOT** recommend, and will not be able to troubleshoot, or warranty, any problems resulting from:

- Magazines of an incorrect caliber
- Non-factory capacity magazines
- Homemade or aftermarket magazine extensions or couplers

**Magazines are wear items that need to be replaced over time.**

Number your magazines for troubleshooting to determine if a particular magazine is a consistent source of problems.

Older magazines may benefit from replacing the magazine spring for reliable operation.

Compare the angle and height of the top round in old magazines to new magazines to see if the feed lips have worn out.

**FM Products will ALWAYS warranty issues when high quality AC-Unity or Circle 10 5.56x45mm magazines are used.**

# **OPERATIONAL CONTROLS**

**Nothing can ever take the place of proper instruction and training.**

FM Products **STRONGLY** recommends you get training on how to safely operate and shoot your firearm from a qualified instructor.

The operational controls of your new firearm are covered in much greater detail in our how-to videos, which can be found on our website [www.FM-Products.com](http://www.FM-Products.com)

## **SAFETY**

The MIKE-102 Gen 2 is equipped with an ambidextrous, manual thumb operated safety that is located at the rear of the lower receiver.

When the safety is in the “safe” position, the trigger is blocked and the weapon will not fire.

When the safety is moved to the “fire” position, by flipping the safety lever down and forward, the trigger can be pulled and the weapon will fire.

The safety can only be engaged when the internal hammer is in the cocked position. If the safety lever will not rotate to the “safe” position then pull back on the charging handle to cock the internal hammer.

## **FIRE CONTROL (TRIGGER SYSTEM)**

The MIKE-102 Gen 2 is equipped with an AR pattern fire control, consisting of an external trigger & internal hammer.

The trigger is operated by pulling on it using the index finger, causing the internal hammer to drop, firing the weapon. The trigger can only be operated when the safety selector is in the “fire” position.

The hammer is automatically cocked by the bolt carrier assembly as the weapon cycles, or when the bolt is manually retracted by the charging handle. The hammer must be cocked for the safety selector to move into the “safe” position.

## **CHARGING HANDLE**

The MIKE-102 Gen 2 is equipped with a non-reciprocating, forward charging handle located inside the front handguard.

This is used to retract the bolt carrier assembly during loading, unloading, and malfunction clearing operations.

**NEVER** push the charging handle forward. Always release the charging handle and allow the internal springs to move it forward.

If you choose to place your support hand in front of the charging handle while operating the firearm take care to ensure your hand does not cause the charging handle to move rearward. Any pulling on the charging handle during its operation may cause the bolt to not fully go into battery, resulting in a “soft strike” malfunction.

The charging handle can be put on the left or right side of the gun. Refer to “Accessorizing Your MIKE-102 Gen 2: 4-Position Charging Handle” for details on how to change the position.

# **OPERATIONAL CONTROLS, CONT'D**

## **MAGAZINE CATCH**

The MIKE-102 Gen 2 is equipped with a magazine catch that locks the magazine into place.

To lock a magazine into place, simply insert the front of the magazine above the pin in the front of the magwell and then rotate the magazine rearward into well of the lower receiver, allowing the tab on the rear of the magazine to latch in place above the magazine catch.

To release a magazine, press forward on the magazine catch lever in front of the trigger guard and rotate the magazine forward, allowing it to drop free from the lower receiver.

## **BOLT STOP**

The MIKE-102 Gen 2 is not equipped with a bolt stop that locks the bolt to the rear.

AC-Unity magazines have metal in the follower that will hold the bolt rearward after the last round has been fired, however the bolt will come forward and go into battery on the empty chamber once the magazine has been removed.

## **EJECTION PORT COVER**

The MIKE-102 Gen 2 is equipped with an ejection port cover to keep dirt and debris out of the action when the rifle is not being fired.

The ejection port cover is manually closed by rotating it up and snapping it into place. The ejection port cover will automatically snap open any time the bolt carrier assembly moves.

# LOADING & RELOADING

When loading your MIKE-102 Gen 2 **ALWAYS** make sure the firearm is pointed in a safe direction, your finger is away from the trigger and the thumb safety is in the “safe” position.

**FM Products STRONGLY suggests “mounting the weapon” by bringing a rifle’s stock to your shoulder, or pushing a pistol forward against the sling, before manipulating the forward charging handle.**

To properly load your weapon:

1. Remove the empty magazine, if needed, and insert a loaded magazine
2. Push forward on the magazine to confirm it is fully locked into place
3. With the weapon mounted, in a safe direction, pull rearward on the forward charging handle, making sure it moves fully rearward in it’s range of motion
4. Quickly release the charging handle, allowing the bolt to drop at full speed, and charge the weapon

**FM Products STRONGLY suggests not “riding the charging handle”, to release the bolt when loading a new magazine.**

If the handle is released too soon, or if the shooter “rides” the handle”, causing the bolt to slow, there may be insufficient momentum to strip the round from the magazine and load it into the chamber.

**Quickly releasing the handle after pulling it rearward, is the correct way to manipulate the charging handle.**

## **LOADING & RELOADING, CONT'D**

To close the bolt on an empty chamber for storage:

1. Remove the magazine, if needed
2. Pull back on the charging handle to expose the chamber
3. Visually check that the last round has ejected and ensure the chamber is empty
4. Slowly allow the charging handle to move forward until the bolt comes to rest on the chamber

A fully loaded magazine spring exerts a great deal of upward force, and can place a substantial amount of pressure on the bolt carrier assembly when inserted.

A magazine loaded to maximum capacity is designed to have the top round stripped off before semi-automatic operation.

FM Products **STRONGLY** suggests that if you want to do “tactical reloads” or “topping off the gun”, where the shooter changes out a partially spent magazine on a closed bolt, that your magazines be downloaded by 2 rounds.

It is a best practice to always retain magazines with ammunition during a “tactical reload”, in these cases the shooter would manually remove the magazine from the gun.

# CLEARING MALFUNCTIONS

**All semi-automatic firearms may experience a malfunction from time to time.**

Most malfunctions are caused by improper maintenance, out of spec ammunition, improperly maintained magazines, or debris that has been introduced to the internal parts of the firearm.

To minimize the frequency of malfunctions, your firearm should be maintained in accordance with this instruction manual.

## STEPS TO CLEAR A MALFUNCTION:

1. Always keep the firearm pointed in a safe direction
2. Keep your finger outside of the trigger guard at all times
3. Take note of the type of malfunction so that remedial maintenance or repair can be performed if necessary
4. Remove the magazine
5. Retract the bolt carrier assembly to its fully rearward position, attempting to clear the malfunction
6. If physical intervention is required to clear the malfunction only use your fingers or a small plastic tool

Metal tools should not be introduced into the action of a firearm as they can cause damage or detonate the primer of the cartridge.

**If you are unable to clear the malfunction, contact [info@FM-Products.com](mailto:info@FM-Products.com) or your local gunsmith for further instructions.**

# FIELD STRIPPING

Field stripping is the quick disassembly of the firearms major components for cleaning and inspection.

**The field stripping of your new firearm is covered in much greater detail in our how-to videos, which can be found on our website [www.FM-Products.com](http://www.FM-Products.com)**

**ALWAYS** wear safety glasses when field stripping the MIKE-102 Gen 2, as components under spring pressure could potentially cause eye injury.

## **FIELD STRIPPING MIKE-102 GEN 2**

1. Remove the magazine.
2. Confirm the firearm is unloaded.

**The majority of negligent discharges happen because of firearm owners skipping step #2.**

3. Make sure the bolt is in the closed position.
4. Push the rear takedown pin and front pivot pin from left to right until it stops.

**We build our receivers tight, so it may require a hammer & punch to tap out the pins on new firearms.**

5. Separate the upper from the lower.
6. Use an 1/8" punch in the rear upper receiver plug to depress the recoil spring guide rod.
7. Slide the upper receiver plug down and out of the upper, freeing the recoil spring assembly. Use your other hand to capture the recoil spring assembly.
8. Pull on the front charging handle, causing the bolt carrier assembly to move rearward.
9. Pull the bolt carrier assembly from the upper.



## **REASSEMBLY**

10. Ensure the bolt is pulled all the way forward in the bolt carrier assembly.
11. Drop the bolt carrier assembly into the upper receiver.
12. Slide the recoil spring assembly into the upper receiver, aligning the guide rod with the recoil spring counterbore in the carrier key.
13. Depress the recoil spring guide rod with an 1/8" punch while sliding the upper receiver plug into the upper.
14. When the upper receiver plug is fully in the upper the recoil spring guide rod should "snap" into place.
15. Reattach the upper on the lower by sliding the front pivot pin and rear takedown pin from right to left.
16. Pull back on the forward charging handle to confirm the bolt carrier assembly moves freely in the upper.

**ALWAYS** field strip, clean, and lubricate your bolt carrier group every 300-500 rounds. **Take care to flush the firing pin channel with gun scrubber and clean the firing pin to remove excess carbon buildup.**

## **FIELD STRIPPING GEN 2 BOLT CARRIER ASSEMBLY**

1. Remove the firing pin retaining pin (cotter pin).
2. Remove the firing pin & return spring.
3. Depress the bolt head fully to the rear, turn the cam pin so the flat is aligned with the carrier key and remove by pulling it out of the bolt carrier. This is a snug fit so ensure the flat on the cam pin is aligned with the side of the gas key.
4. The bolt assembly can now be removed by pulling it out of the front of the bolt carrier.
5. No further disassembly is required for routine cleaning.
6. Clean and oil parts.
7. Reverse steps 5 thru 1 for reassembly.

The bolt assembly in your MIKE-102 Gen 2 is equipped with a patent pending firing pin & reset spring.

## FIELD STRIPPING, CONT'D

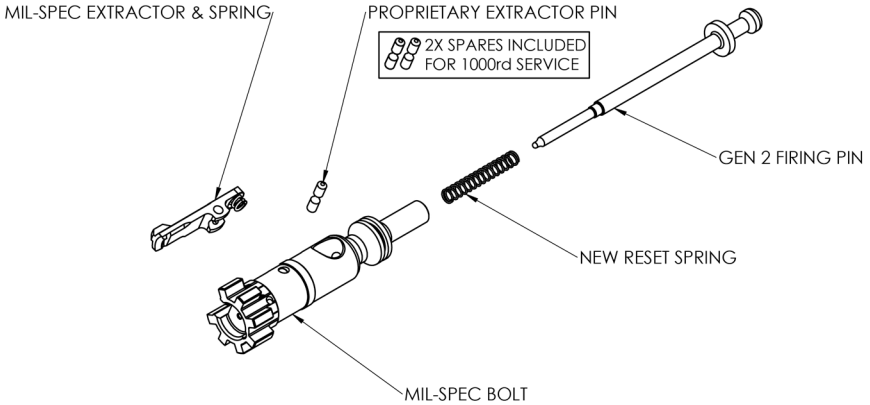

The procedure to field strip your bolt carrier group does not change with the addition of the Gen 2 firing pin & reset spring. The Gen 2 firing pin features a retaining boss which should hold the reset spring in place during assembly and disassembly.

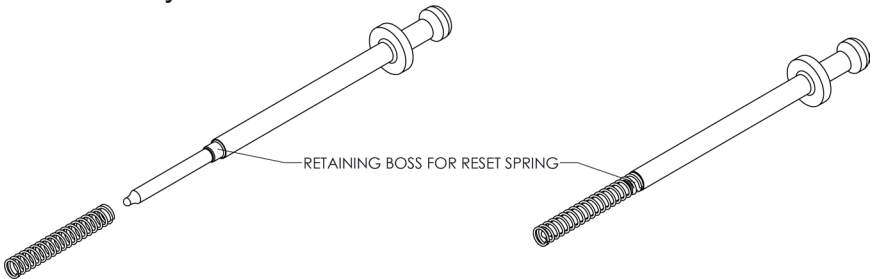

### EXTRACTOR REMOVAL

We recommend you perform a detailed cleaning every 1000 rounds which includes removing the extractor. **Ensure the reset spring has been removed from the bolt before attempting to remove the extractor pin.**

**NEVER** use the tip of the firing pin to push out an extractor pin. Use the firing pin retainer, or a small punch if available, to push out the extractor pin. Using the firing pin could damage the tip and reduce protrusion.

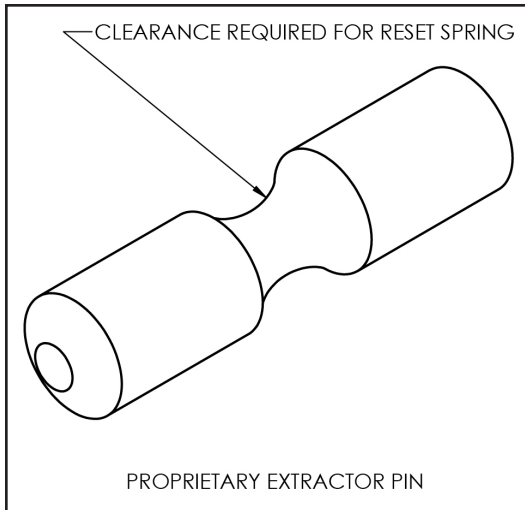

The Gen 2 firing pin & reset spring use a proprietary extractor pin. You cannot use a mil-spec extractor pin with the reset spring..

The proprietary extractor pin may split down the middle during operation, however because the extractor pin is captured by the carrier when the bolt is installed this does not impact proper extractor function.

**To reiterate, the proprietary extractor pin is designed to function properly even if it has split in two.**

FM Products does not recommend reusing the proprietary extractor pins once removed, which is why we have provided additional proprietary extractor pins for replacement every 1000 rounds.

FM Products recommends you replace the reset spring whenever you replace the other springs in your bolt, which is approximately every 3000 rounds. Bolt service kits are available which include all the recommended replacement parts and additional proprietary extractor pins.

# **BREAK-IN & MAINTENANCE**

The MIKE-102 Gen 2 uses an AR-style direct impingement system which requires regular lubrication to function reliably.

FM Products recommends a 500 round “break-in” period for any new firearm, where extra care should be given to ensure that adequate cleaning and lubrication is used.

When a direct impingement firearm is brand new it is not uncommon to see more malfunctions during the first 100 rounds, as this is when the gas rings and other internal components are “wearing in”. Please make sure the internals are well lubricated to have a successful break-in period.

## **FM Products are shipped coated in a corrosion inhibitor. THIS IS NOT LUBRICATION!**

Wipe off all corrosion inhibitor and properly lubricate before shooting your firearm for the first time.

We recommend spraying oil into the bore of the upper receiver, and coating the bolt and carrier with oil before shooting the weapon the for first time. FM Products likes to run our guns wet, especially when the gun is new and the parts are learning to play well together.

ONLY use cleaning and lubrication products designed for firearms. Many other products for automotive or industrial applications are NOT suitable for firearms and may void your warranty.

For best results, before every shooting session we recommend you perform a “quick clean” by wiping down your bolt carrier assembly and re-lubricating your bolt carrier assembly and inside the upper receiver every time you shoot your gun.

Use a high quality, light gun oil when lubricating, like Rem Oil or CLP in the aerosol can, which can quickly spray down the bolt carrier assembly.

**For those new to direct impingement guns please note:** it is crucial to get a small amount of light gun oil into the internals of your bolt carrier group. Keeping the bolt shoulder, cam pin slot, gas rings, and bolt tail lightly lubricated will increase reliability and longevity.

A small amount of gun grease is suitable for high wear areas like the cam pin, carrier bearing surfaces, recoil spring guide rod, and the internal surfaces where the front charging handle interfaces with the handguard & upper receiver.

Performing the break-in during cold weather can be problematic as the viscosity of your gun lubrication changes dramatically. We do NOT recommend using grease on the bolt carrier assembly in cold environments. This can effect feeding and manifest in seemingly “random” malfunctions. If you are shooting in cold weather with thicker lubrication try warming the gun up to 70 degrees before break-in.

During break-in we recommend loading magazines to 60% capacity to reduce pressure on the bolt carrier and ensure reliable function.

Perform a thorough cleaning and visual inspection of your bolt carrier assembly and other internal components every 500 rounds, or as needed.

**Detailed cleaning & lubrication instructions are beyond the scope of the quick start guide and are best explained via videos, which can be found on our website [www.FM-Products.com](http://www.FM-Products.com)**

# **TROUBLESHOOTING TIPS**

**Always troubleshoot any malfunctions in this order:**

## **1. CLEAN & LUBRICATE (Page 17)**

Improper cleaning & lubrication (aka dry & dirty) is the number one cause of malfunctions. Perform a thorough cleaning every 500 rounds and check for worn components, replacing as needed. Best practice is to always quick clean and lubricate the gun prior to shooting it.

## **2. AMMUNITION (Page 6)**

Use high-quality, factory loaded, brass cased ammunition. Test a different type of ammunition to ensure you don't have a bad batch. Ammunition can have a wide range of tolerance. Know that steel case ammunition may have soft strikes or stuck chambers.

## **3. MAGAZINES (Page 8)**

Use high quality AK-102 pattern 5.56x45mm magazines like AC-Unity and Circle 10. Test multiple magazines to see if the problem is linked to a particular magazine. Magazines do wear out over time and need to be replaced.

## **4. CONTACT CUSTOMER SUPPORT**

If the malfunction continues to persist please contact us at [info@FM-Products.com](mailto:info@FM-Products.com) FM Products answers customer service emails 7 days a week.

**NOTE: FM Products cannot provide technical support or troubleshoot components that we do not manufacture.**

# **ACCESSORIZING YOUR MIKE-102 GEN 2**

## **PROPRIETARY PARTS**

Many of the components in the MIKE-102 Gen 2 are proprietary and therefore not interchangeable with standard AR pattern components.

In particular the gas block, barrel, barrel nut, bolt carrier, and carrier key are all proprietary, patent pending, or patented items and should NOT be disassembled. Removing, or disassembling, the barrel nut, gas block or bolt carrier key may void your warranty!

The rest of this section will detail the components that are compatible with other accessories.

## **4-POSITION CHARGING HANDLE**

The forward charging handle on your MIKE-102 Gen 2 can be put in four different positions, left or right, up or down.

Changing the position of the charging handle is covered in much greater detail in our how-to videos, which can be found on our website [www.FM-Products.com](http://www.FM-Products.com)

Please see technical document **2308013 - REVISED GEN 2 CHARGING HANDLE DISASSEMBLY INSTRUCTIONS** for updated instructions on how to remove the charging handle.

The charging handle is held in place by two #10-32 set screw that comes in from the front. You will need a long 3/32" hex key to loosen the two set screws.

If you have a two-piece charging handle trolley, indicated by a hex shape at the rear where it pushes against the carrier key,

## **ACCESSORIZING YOUR FM-15 GEN 2, CONT'D**

then the rear portion of the trolley is also holding in the charging handle. You will need to remove the handguard and use a 7/32" socket to loosen the rear portion of the trolley to remove the charging handle.

Be sure to use a thread locking compound, like Blue Loctite, when reassembling your charging handle.

**Do not exceed 15-20in/lb when re-tightening.**

The technical specifications of the charging handle is available for aftermarket manufacturers who would like to create new charging handle designs. Contact us at [info@FM-Products.com](mailto:info@FM-Products.com)

### **GEN 2 HANDGUARD**

The Gen 2 handguard & barrel nut is proprietary to the MIKE-102 Gen 2, and because it is integral to the forward charging system it is not interchangeable with any other manufacturer's handguards.

The Gen 2 handguard can be removed by using an IP27 Torx Plus to remove the two #10-32 x 1 1/4" screws. Do not lose the split washers or the charging handle spring when removing.

**Do not exceed 15-20in/lb when re-tightening.**

Ensure the handguard is properly aligned by pulling back on the front charging handle without the bolt carrier assembly or recoil spring assembly installed.

The Gen 2 barrel nut is **NOT TO BE REMOVED**, and may void your warranty by doing so. If the barrel or upper receiver



needs to be serviced for any reason it must be sent back to FM Products.

Contact us at [info@FM-Products.com](mailto:info@FM-Products.com) if you need service.

## **SIGHTS & OPTICS**

The MIKE-102 Gen 2 upper receiver & handguard are exactly 1/4" taller than standard AR upper receivers, to accommodate the front charging handle and captured recoil system.

FM Products used standard AR-15 sights, optics, and optic mounts during development without issue.

## **MUZZLE DEVICES**

The MIKE-102 Gen 2 has industry standard 1/2"-28 threads on our barrels, and features 9/16" wrench flats near the muzzle.

The wrench flats are intended to be used to support the barrel with a wrench when torque is applied loosening or tightening a muzzle device.

ALWAYS work with a competent gunsmith who will use proper fixtures and tools to prevent damage to the barrel and upper receiver when changing out muzzle devices.

## **STOCK ADAPTER**

The MIKE-102 Gen 2 captured recoil system requires the use of one of our stock adapters, which features an integrated recoil buffer as part of the threaded adapter.

We have multiple options for stock adapters, including a fixed, folding, and picatinny rail adapters. Please contact us at [info@FM-Products.com](mailto:info@FM-Products.com) for more information.

## **ACCESSORIZING YOUR FM-15 GEN 2, CONT'D**

Use of the MIKE-102 Gen 2 Upper receiver without one of our stock adapters will damage the upper receiver and bolt carrier assembly and may void the warranty.

### **FIRE CONTROL (TRIGGER SYSTEM)**

The MIKE-102 Gen 2 will accept any AR pattern triggers, including most “drop-in” triggers.

FM Products **STRONGLY** suggests the use of Hiperfire triggers for an aftermarket drop-in trigger.

FM Products is unable to test all of the numerous aftermarket triggers on the market, and therefore cannot advise or guarantee that another manufacturer’s product will work in our firearm.

FM Products **STRONGLY** recommends choosing a Mil-Spec GI style trigger that offers ample hammer / disconnector engagement.

Burst fire is ALWAYS the result of an issue with the fire control, and is generally due to the trigger not having sufficient disconnector engagement, or disconnectors wearing out.

FM Products can ONLY warranty the fire control that FM Products installed in your firearm.

ANY burst fire issues with an aftermarket fire control MUST be taken up with that trigger manufacturer or the gunsmith that installed the trigger.

FM Products does not provide technical support or troubleshooting of binary triggers, forced reset triggers, or any other aftermarket triggers.

If you are having an issue with the trigger included with your MIKE-102 Gen 2, contact us immediately at [info@FM-Products.com](mailto:info@FM-Products.com)

## **BOLT CARRIER ASSEMBLY**

The bolt, extractor, and firing pin retainer (cotter pin) in the MIKE-102 Gen 2 are mil-spec components, and therefore can be replaced by any manufacturer's parts that conform to the mil-spec.

The bolt in your MIKE-102 Gen 2 is equipped with a patent pending firing pin & reset spring.

This new firing pin & reset spring are a safety upgrade to prevent slam fire or burst fire malfunctions that can occur when a mil-spec free floating firing pin is combined with non-mil-spec ammunition using soft primers.

To create the space needed in the bolt assembly for the Gen 2 firing pin & reset spring the use of a proprietary extractor pin is required. No other extractor pin should be used.

Use of a mil-spec extractor pin with the Gen 2 firing pin & reset spring could result in damage to the firing pin, bolt, or bolt carrier, and may void the warranty.

The MIKE-102 Gen 2 features a proprietary carrier, carrier key, and cam pin.

Contact us at [info@FM-Products.com](mailto:info@FM-Products.com) if you need service on the carrier, carrier key, or cam pin.

## **ACCESSORIZING YOUR FM-15 GEN 2, CONT'D**

### **LOWER RECEIVER**

The MIKE-102 Gen 2 upper assembly was designed specifically to work with the MIKE-102 lower receiver. FM Products does not recommend using any other manufacturers lower receiver, and doing so may void your warranty.

The MIKE-102 Gen 2 captured recoil system requires the use of one of our stock adapters, which features an integrated recoil buffer as part of the threaded adapter.

Use of the MIKE-102 Gen 2 upper assembly on a lower without one of our stock adapters will damage the upper receiver and bolt carrier assembly, and may void your warranty.

### **A NOTE ON AFTERMARKET ACCESSORIES**

We support every customer's choice to customize and accessorize their personal firearm as they see fit, however no manufacturer, FM Products included, can support, troubleshoot, or be held responsible for products and accessories that they did not manufacture.

Please contact the accessory manufacturer, or the gunsmith who installed it, when problems arise using aftermarket components we don't formally recommend or support.

# STATE-BY-STATE WARNINGS

Some states require by law that specified warning notices in “larger-than-normal” type be conspicuously included by the manufacturer, distributor, or retailer with firearms sold in that state.

Since our products may be sold in those states we include the following:

## **CALIFORNIA:** **WARNING**

“Children are attracted to and can operate firearms that can cause severe injuries or death. Prevent child access by always keeping guns locked away and unloaded when not in use. If you keep a loaded firearm where a child obtains and improperly uses it, you may be fined or sent to prison.”

## **ADVERTENCIA**

“Los niños se sienten atraídos y se puede operar las armas de fuego que pueden causar lesiones graves o la muerte. Evitar el acceso niño siempre manteniendo las armas bajo llave y descargadas cuando no esté en uso. Si usted mantiene un arma de fuego cargada en que un niño obtiene y utiliza inadecuadamente, usted puede recibir una multa de enviado a la cárcel.”

## **STATE-BY-STATE WARNINGS, CONT'D**

### **CONNECTICUT:**

“UNLAWFUL STORAGE OF A LOADED FIREARM MAY RESULT IN IMPRISONMENT OR FINE”

### **FLORIDA:**

“IT IS UNLAWFUL, AND PUNISHABLE BY IMPRISONMENT AND FINE, FOR ANY ADULT TO STORE OR LEAVE A FIREARM IN ANY PLACE WITHIN THE REACH OR EASY ACCESS OF A MINOR UNDER 18 YEARS OF AGE OR TO KNOWINGLY SELL OR OTHERWISE TRANSFER OWNERSHIP OR POSSESSION OF A FIREARM TO A MINOR OR A PERSON OF UNSOUND MIND”

### **MAINE:**

“ENDANGERING THE WELFARE OF A CHILD IS A CRIME. IF YOU LEAVE A FIREARM AND AMMUNITION WITHIN EASY ACCESS OF A CHILD, YOU MAY BE SUBJECT TO FINE, IMPRISONMENT OR BOTH. KEEP FIREARMS AND AMMUNITION SEPARATE. KEEP FIREARMS AND AMMUNITION LOCKED UP. USE TRIGGER LOCKS.”

## **MARYLAND:**

“WARNING: Children can operate firearms which may cause death or serious injury. It is a crime to store or leave a loaded firearm in any location where an individual knew or should have known that an unsupervised minor would gain access to the firearm. Store your firearm responsibly!”

## **MASSACHUSETTS:**

“WARNING FROM THE MASSACHUSETTS ATTORNEY GENERAL: This handgun is not equipped with a device that fully blocks use by unauthorized users. More than 200,000 firearms like this are stolen from their owners every year in the United States. In addition, there are more than a thousand suicides each year by younger children and teenagers who get access to firearms. Hundreds more die from accidental discharge. It is likely that many more children sustain serious wounds, or inflict such wounds accidentally on others. In order to limit the chance of such misuse, it is imperative that you keep this weapon locked in a secure place and take steps necessary to

## **STATE-BY-STATE WARNINGS, CONT'D**

limit the possibility of theft or accident. Failure to take reasonable preventive steps may result in innocent lives being lost, and in some circumstances may result in your liability for these deaths.”

“IT IS UNLAWFUL TO STORE OR KEEP A FIREARM, RIFLE, SHOTGUN, OR MACHINE GUN, IN ANY PLACE UNLESS THAT WEAPON IS EQUIPPED WITH A TAMPER-RESISTANT SAFETY DEVICE OR IS STORED OR KEPT IN A SECURELY LOCKED CONTAINER.”

### **NEW JERSEY:**

“IT IS A CRIMINAL OFFENSE TO LEAVE A LOADED FIREARM WITHIN EASY ACCESS OF A MINOR.”

### **NEW YORK CITY, NY:**

“THE USE OF A LOCKING DEVICE OR SAFETY LOCK IS ONLY ONE ASPECT OF RESPONSIBLE FIREARMS STORAGE. FOR INCREASED SAFETY, FIREARMS SHOULD BE STORED UNLOADED AND LOCKED IN A LOCATION THAT IS BOTH



SEPARATE FROM THEIR AMMUNITION AND INACCESSIBLE TO CHILDREN AND OTHER UNAUTHORIZED PERSONS.”

**NORTH CAROLINA:**

“IT IS UNLAWFUL TO STORE OR LEAVE A FIREARM THAT CAN BE DISCHARGED IN A MANNER THAT A REASONABLE PERSON SHOULD KNOW IS ACCESSIBLE TO A MINOR.”

**TEXAS:**

“IT IS UNLAWFUL TO STORE, TRANSPORT, OR ABANDON AN UNSECURED FIREARM IN A PLACE WHERE CHILDREN ARE LIKELY TO BE AND CAN OBTAIN ACCESS TO THE FIREARM.”

**WISCONSIN:**

“IF YOU LEAVE A LOADED FIREARM WITHIN THE REACH OR EASY ACCESS OF A CHILD YOU MAY BE FINED OR IMPRISONED OR BOTH IF THE CHILD IMPROPERLY DISCHARGES, POSSESSES, OR EXHIBITS THE FIREARM.”

# **TROUBLESHOOTING TIPS**

**Always troubleshoot any malfunctions in this order:**

## **1. CLEAN & LUBRICATE (Page 17)**

Improper cleaning & lubrication (aka dry & dirty) is the number one cause of malfunctions. Perform a thorough cleaning every 500 rounds and check for worn components, replacing as needed. Best practice is to always quick clean and lubricate the gun prior to shooting it.

## **2. AMMUNITION (Page 6)**

Use high-quality, factory loaded, brass cased ammunition. Test a different type of ammunition to ensure you don't have a bad batch. Ammunition can have a wide range of tolerance. Know that steel case ammunition may have soft strikes or stuck chambers.

## **3. MAGAZINES (Page 8)**

Use high quality AK-102 pattern 5.56x45mm magazines like AC-Unity and Circle 10. Test multiple magazines to see if the problem is linked to a particular magazine. Magazines do wear out over time and need to be replaced.

## **4. CONTACT CUSTOMER SUPPORT**

If the malfunction continues to persist please contact us at [info@FM-Products.com](mailto:info@FM-Products.com) FM Products answers customer service emails 7 days a week.

**NOTE: FM Products cannot provide technical support or troubleshoot components that we do not manufacture.**



## **QUESTIONS? We're here to help!**

Please contact us at [info@FM-Products.com](mailto:info@FM-Products.com)

Foxtrot Mike Products answers customer service emails 7 days a week.

**Lots of how-to videos available at  
[www.FM-Products.com](http://www.FM-Products.com)**

Follow us on Instagram @FoxtrotMikeProducts and be sure to tag us in your photos!

**#Abracadabra #FoxtrotFridays**



## **QUESTIONS? We're here to help!**

Please contact us at [info@FM-Products.com](mailto:info@FM-Products.com)

Foxtrot Mike Products answers customer service emails 7 days a week.

**Lots of how-to videos available at  
[www.FM-Products.com](http://www.FM-Products.com)**

Follow us on Instagram [@FoxtrotMikeProducts](https://www.instagram.com/FoxtrotMikeProducts) and be sure to tag us in your photos!

**#Abracadabra #FoxtrotFridays**

# MIKE-15/102 Gen 2 Firing Pin & Reset Spring Update

## HOW-TO VIDEO AVAILABLE AT [WWW.FM-PRODUCTS.COM](http://WWW.FM-PRODUCTS.COM)

The bolt in your MIKE-15/102 Gen 2 upper receiver is equipped with Foxtrot Mike Products new, patent pending, Gen 2 firing pin & reset spring.

This new firing pin & reset spring are a safety upgrade to prevent slam fire malfunctions that could potentially occur when a mil-spec free floating firing pin is combined with non-mil-spec ammunition using soft primers.

To create the space needed in the bolt assembly for the Gen 2 firing pin & reset spring the use of a proprietary extractor pin is required.

**DO NOT USE A MIL-SPEC EXTRACTOR PIN WITH THE FIRING PIN RESET SPRING.**

Consumers may choose to use a mil-spec free floating firing pin and extractor pin, assuming the firing pin spring is removed.

*Mil-spec 5.56x45mm ammunition uses No.41 primers, they are specifically designed to mitigate slam fires. Non-mil-spec ammunition may use softer primers, which may increase likelihood of a slam fire.*

The MIKE-15/102 Gen 2 firing pin & reset spring are compatible with all mil-spec bolts and are available as a stand alone kit for purchase as a safety upgrade.

**Please contact us at [info@FM-Products.com](mailto:info@FM-Products.com) with any questions.  
FM Products answers customer service emails 7 days a week.**

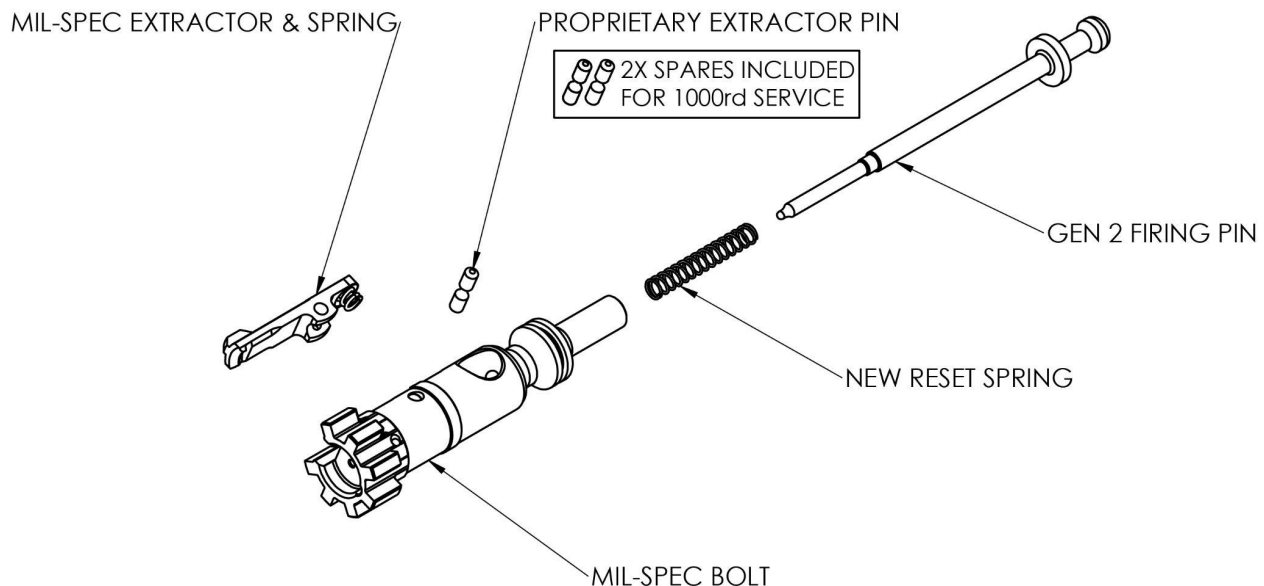

**WARNING:** Always wear eye protection when working with firearms. Components under spring pressure could potentially cause eye injury.

**WARNING:** Always ensure the magazine is removed from your firearm and confirm your firearm is unloaded before beginning.

**MORE INSTRUCTIONS ON THE BACK**

REV B 9/23

## FIELD STRIPPING

**ALWAYS** field strip, clean, and lubricate your bolt carrier group every 300-500 rounds. **Take care to flush the firing pin channel with gun scrubber and clean the firing pin to remove excess carbon buildup.**

The procedure to field strip your bolt carrier group does not change with the addition of the Gen 2 firing pin & reset spring. The Gen 2 firing pin features a retaining boss which should hold the reset spring in place during assembly and disassembly.

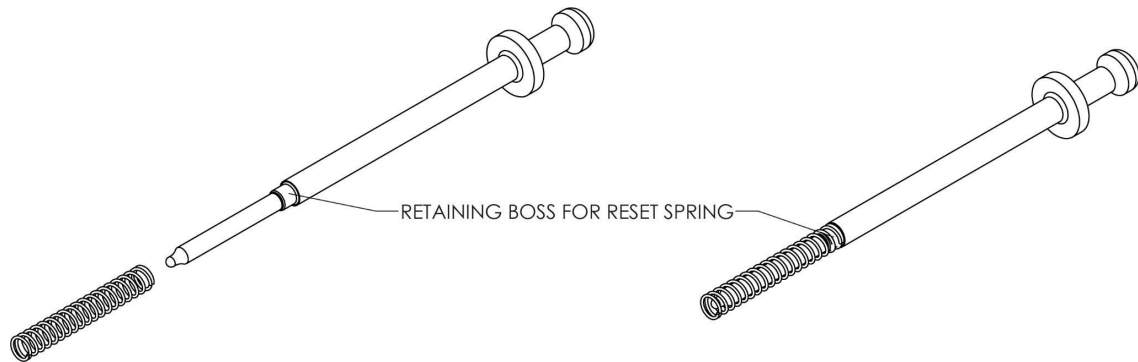

If the reset spring has slipped off this boss during operation then tap the tail of the bolt on a hard surface to bring the reset spring rearward, and use the tip of the firing pin, or a small pick if available, to fish out the spring.

## EXTRACTOR REMOVAL

We recommend you perform a detailed cleaning every 1000 rounds which includes removing the extractor. **Ensure the reset spring has been removed from the bolt before attempting to remove the extractor pin.**

**NEVER** use the tip of the firing pin to push out an extractor pin. Use the firing pin retainer, or a small punch if available, to push out the extractor pin. Using the firing pin could damage the tip and reduce protrusion.

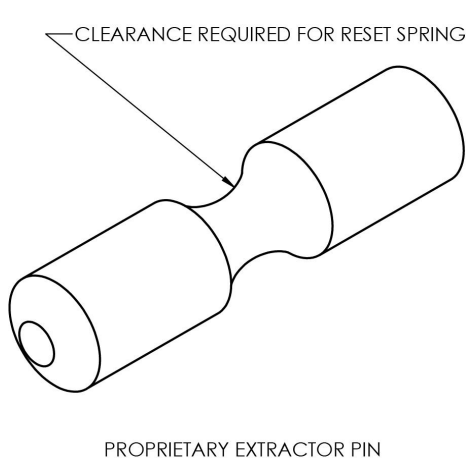

The Gen 2 firing pin & reset spring use a proprietary extractor pin. You cannot use a mil-spec extractor pin with the reset spring..

The proprietary extractor pin may split down the middle during operation, however because the extractor pin is captured by the carrier when the bolt is installed this does not impact proper extractor function.

**To reiterate, the proprietary extractor pin is designed to function properly even if it has split in two.**

FM does not recommend reusing the proprietary extractor pins once removed, which is why we have provided additional proprietary extractor pins for replacement every 1000 rounds.

FM recommends you replace the reset spring whenever you replace the other springs in your bolt, which is approximately every 3000 rounds. Bolt service kits are available which include all the recommended replacement parts and additional proprietary extractor pins.

**Please contact us at [info@FM-Products.com](mailto:info@FM-Products.com) with any questions.  
FM Products answers customer service emails 7 days a week.**

# MIKE-15/102 Gen 2 Picatinny Rail Adapter Installation Instructions

## HOW-TO VIDEO AVAILABLE AT [WWW.FM-PRODUCTS.COM](http://WWW.FM-PRODUCTS.COM)

The MIKE-15/102 Gen 2 upper receiver's captured recoil system requires the use of one of our stock or picatinny rail adapters, which features an integrated recoil buffer as part of the threaded adapter.

**Use of the MIKE-15/102 Gen 2 Upper receiver without one of our threaded buffer adapters will damage the upper receiver, bolt carrier assembly, & lower receiver, and may void the warranty.**

Please contact us at [info@FM-Products.com](mailto:info@FM-Products.com) with any questions or concerns.  
FM Products answers customer service emails 7 days a week.

**WARNING:** Always wear eye protection when working with firearms. Components under spring pressure could potentially cause eye injury.

**WARNING:** Always ensure the magazine is removed from your firearm and confirm your firearm is unloaded before beginning.

**WARNING:** As a firearm owner, it is your job to know and comply with the local, state and federal laws regarding firearms ownership. Please check with your local authorities for current laws and regulations in your locality.

<b>INCLUDED COMPONENTS:</b> Picatinny Rail Adapter Threaded Buffer Adapter #6-32 Set Screw 1/16" Hex Key Plastic Shim Rubber Band Mil-Spec Buffer Retainer Buffer Retainer Spring	<b>REQUIRED TOOLS:</b> 3/8" Drive Ratchet Handle with Extension  <b>SUGGESTED TOOLS:</b> Magwell Vise Block Bench Vise All Purpose Grease
---	---

**FULLY READ THESE INSTRUCTIONS BEFORE BEGINNING SO YOU UNDERSTAND HOW ALL OF THE PARTS WORK TOGETHER.**

### INSTALLATION STEPS:

1. We suggest securing your lower receiver in a bench vise using a magwell vise block.
2. Begin with the takedown pin\* and takedown pin detent\* installed in the lower receiver. We suggest greasing these parts before installation. Set the takedown pin detent spring\* aside. (\*parts not included)
3. If the #6-32 set screw is in the picatinny rail adapter then remove it using the 1/16" hex key and set it aside.

**THERE ARE BOTH RIGHT HANDED THREADS (BIG END) AND LEFT HANDED THREADS (SMALL END) ON THE THREADED BUFFER ADAPTER.**

**BE CAREFUL NOT TO CROSS THREAD THE PLASTIC THREADS WHEN STARTING IT INTO THE LOWER RECEIVER (RIGHT HANDED) OR PICATINNY RAIL ADAPTER (LEFT HANDED).**

**ALWAYS START BY HAND AND DO NOT FORCE IT. THE ADAPTER SHOULD ROTATE FREELY.**

**DO NOT USE THREAD LOCKER ON THE THREADED BUFFER ADAPTER. IT IS MECHANICALLY LOCKED INTO PLACE BY THE BUFFER RETAINER.**

4. Begin threading in the threaded buffer adapter into the lower receiver with the smaller threads facing rearward and the sprocket shape facing forward. Stop when only one complete revolution of the larger threads remains sticking out past the rear face of the lower receiver.
5. Install the buffer retainer and spring into the lower receiver. Use the plastic shim under the sprocket shape of the threaded buffer adapter to hold down the buffer retainer. Secure the shim in place using the rubber band around the pistol grip.
6. Install an extension onto the 3/8" drive ratchet handle. Set the ratchet to spin counter clockwise (lefty loosey), and insert the end of the extension into the square opening on the front of the threaded buffer adapter.
7. Use a counter clockwise motion (lefty loosey) to start the picatinny rail adapter onto the smaller threads of the threaded buffer adapter. You only need one complete revolution, just get it started and stop. Remember, the threaded hole in the picatinny rail adapter and the small end of the threaded buffer are both **LEFT HAND THREADS**.
8. Use your free hand to hold the picatinny rail adapter in alignment with the lower receiver, and begin spinning the ratchet handle counter clockwise. This should draw these two parts together. Ensure that the buffer retainer is being held down and out of the way by the plastic shim. Continue tightening the threaded buffer adapter until the picatinny rail adapter is snug against the back of the lower receiver. **DO NOT OVERTIGHTEN**.
9. If the threaded buffer adapter bottoms out inside of the picatinny rail adapter, leaving a gap between the picatinny rail adapter and the back of the lower receiver, you will need to reverse the direction of the ratchet to clockwise (righty tighty), and separate the two pieces just far enough to be able to spin the picatinny rail adapter on the threaded buffer adapter by one revolution counter clockwise, which will back it off from the lower receiver. Repeat from step 8, ensuring that no gap remains between the picatinny rail adapter and the rear of the lower receiver.
10. The sprocket shape of the threaded buffer adapter should protrude past the forward face of the upper receiver, **THIS IS NORMAL AND NECESSARY**, it allows the MIKE-15 Gen 2 carrier to come to a stop without damaging your lower receiver. **NEVER MODIFY THE THREADED BUFFER ADAPTER TO WORK WITH OTHER UPPER RECEIVERS**.
11. With the picatinny rail adapter snug against the rear of the lower receiver, pull the plastic shim out, allowing the buffer retainer to come up and engage with the sprocket shape of the threaded buffer adapter.
12. If the buffer detent does not align with one of the grooves in the sprocket shape then use the ratchet handle to carefully tighten the threaded buffer adapter counter clockwise (lefty loosey) until the next groove lines up and the buffer retainer snaps into place, mechanically locking it in.
13. If the sprocket shape is too far rearward to lock in with the mil-spec buffer retainer then you will need to reinsert the plastic shim, reverse the direction of the ratchet to spin clockwise (righty tighty), and separate the two pieces just far enough to be able to spin the picatinny rail adapter on the threaded buffer adapter by one revolution clockwise, which will bring it towards the lower receiver. Repeat from step 8, ensuring that the buffer retainer engages with the sprocket groove.
14. Insert the takedown pin detent spring into the lower receiver through the hole at the rear of the picatinny rail adapter. Thread in the #6-32 set screw and tighten until it's snug against the rear of the lower receiver.
15. Rotate your takedown pin to confirm the detent is engaged in the slot BEFORE function testing.
16. If you ever have to remove your picatinny rail adapter you will need to depress the buffer retainer with a pick or small screwdriver and hold it down with the plastic shim, before attempting to unthread the threaded buffer adapter with the ratchet and extension.



# MIKE-15/102 Gen 2 3-Position Gas Block Update

HOW-TO VIDEO AVAILABLE AT [WWW.FM-PRODUCTS.COM](http://WWW.FM-PRODUCTS.COM)

The gas system in your MIKE15/102 Gen 2 upper receiver is equipped with Foxtrot Mike Products new, patent pending, Gen 2 3-Position Gas Block.

This new 3-Position gas block is an upgrade to help regulate gas pressure and carrier velocity when using various types of ammunition or a silencer.

## OPERATION

Gas blocks get hot during use! We **ALWAYS** recommend using a small flat head screwdriver, or similar tool, to rotate the gas regulator between settings.

The click adjustable gas regulator features three different positions. The arrow on the right side of the gas block indicates what position is currently selected.

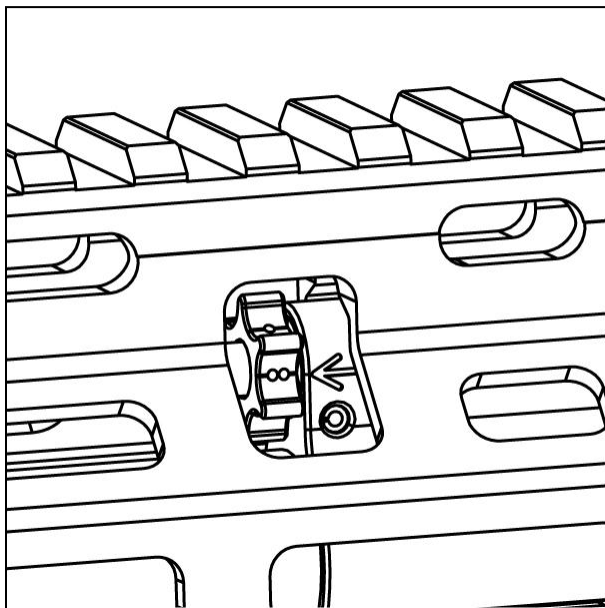

**SUPPRESSED (1-DOT)** - This setting has the smallest gas port, which restricts the gas as much as possible, for when you're running a silencer with high back pressure.

**STANDARD (2-DOT)** - This setting has an intermediate sized gas port. It was calculated to properly cycle and lock back on full powered, factory loaded, domestically produced mil-spec ammunition.

**DIRTY (3-DOT)** - This setting has the largest gas port, set-up to allow more gas through to cycle a bolt-carrier that is dirty or under lubricated. This is also the correct setting for running imported, underpowered ammunition.

The gas regulator shown on the left is in the Standard (2-dot) position.

The gas regulator is setup to only rotate 180 degrees and then come to a complete stop. Always make sure you're turning the regulator in the correct direction.

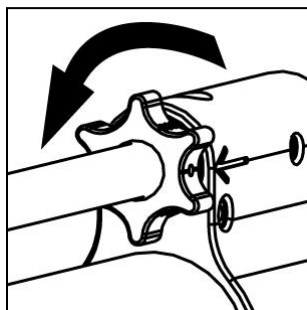

If the gas block arrow indicates you are on the suppressed (1-dot) setting, then you can only rotate counterclockwise to increase gas flow. (shown left)

If the gas block arrow indicates you are on the dirty (3-dot) setting, then you can only rotate clockwise to restrict gas flow. (shown right)

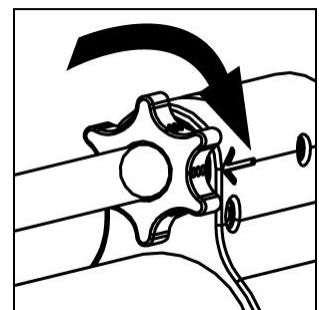

Please contact us at [info@FM-Products.com](mailto:info@FM-Products.com) with any questions.  
FM Products answers customer service emails 7 days a week.

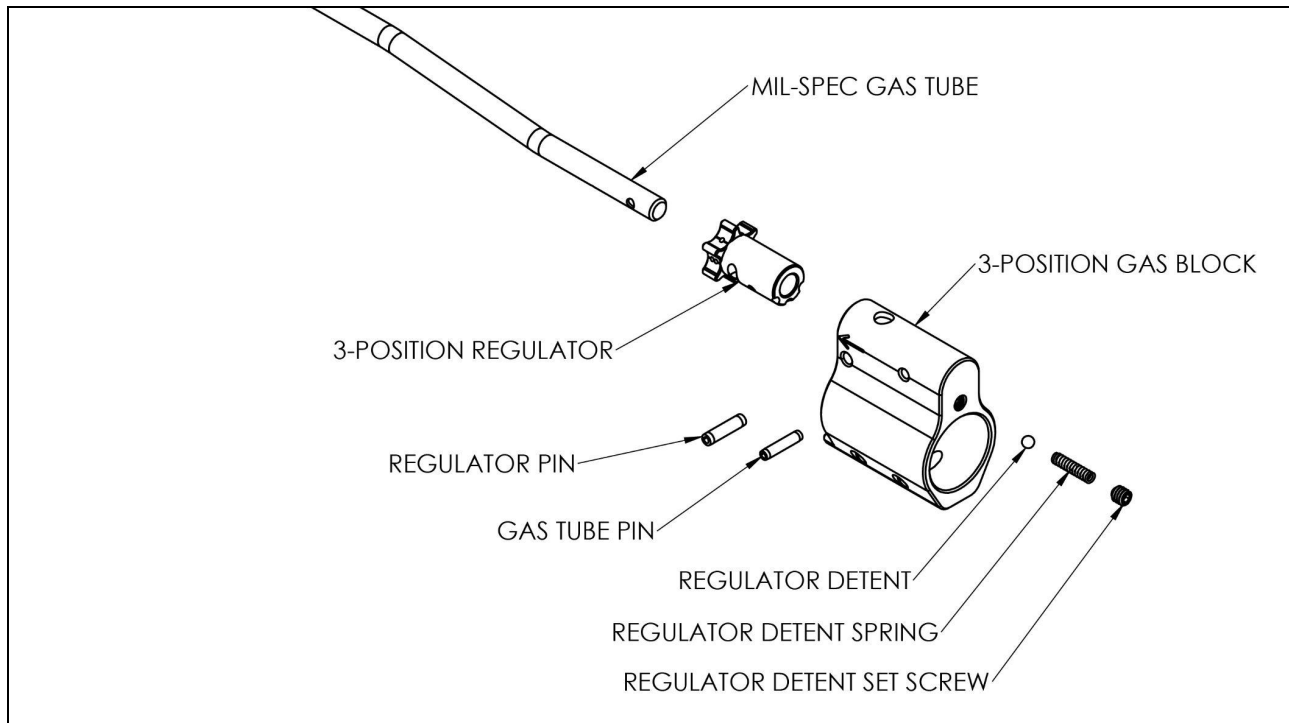

## MAINTENANCE

Like any moving part on a firearm, the Gen 2 3-Position gas block requires cleaning and maintenance.

Whenever you field strip and clean your bolt carrier group (every 300-500 rounds) we recommend the following procedure.

1. With the bolt carrier group removed, prop up your upper receiver in a vertical position, muzzle side down on a shop rag to catch any oil.
2. Using a tube nozzle to reach inside the upper receiver, spray a shot of synthetic gun oil down the gas tube, with the intention of soaking oil into the interior of the gas regulator.
3. Carefully spray synthetic gun oil on the outside of the gas tube where it enters the gas regulator, with the intention of soaking oil in between the gas tube and regulator.
4. If the regulator is really stuck or dirty you may need to pull the handguard and spray synthetic gun oil into the inspection port on the top of the gas block, with the intention of soaking oil down into the regulator.
5. Give the synthetic gun oil at least an hour to soak into the assembly and loosen the carbon fouling, then begin working the regulator back and forth until it moves freely.

Keeping the regulator lubricated and moving freely between range sessions will help prevent it becoming bound up with carbon fouling.

If the regulator becomes bound up due to lack of maintenance, or from excessively dirty ammunition, it can be disassembled and thoroughly cleaned. It requires driving out the regulator and gas tube pins using a hammer and punch. **Spring pins are single use and should not be reused.**

Use a high temperature synthetic grease during reassembly to help keep the detent, spring, and regulator moving freely.

**HOW-TO VIDEO AVAILABLE AT [WWW.FM-PRODUCTS.COM](http://WWW.FM-PRODUCTS.COM)**

**Please contact us at [info@FM-Products.com](mailto:info@FM-Products.com) with any questions.  
FM Products answers customer service emails 7 days a week.**

**TOOLS REQUIRED**

- 1. FLAT HEAD SCREWDRIVER OR 1/8" PUNCH (STEP 1)
- 2. IP27 TORX DRIVER (STEP 2)
- 3. 7/32" WRENCH (STEP 4)
- 4. LONG 3/32" HEX KEY (STEP 5)

REV.	DESCRIPTION	DATE	APPROVED
A	PRELIMINARY RELEASE	9/5/23	A. TROUT

**STEP 1: USE FLAT HEAD SCREWDRIVER OR 1/8" PUNCH TO FIELD STRIP RECOIL SPRING ASSEMBLY & BOLT-CARRIER GROUP PER MANUAL**

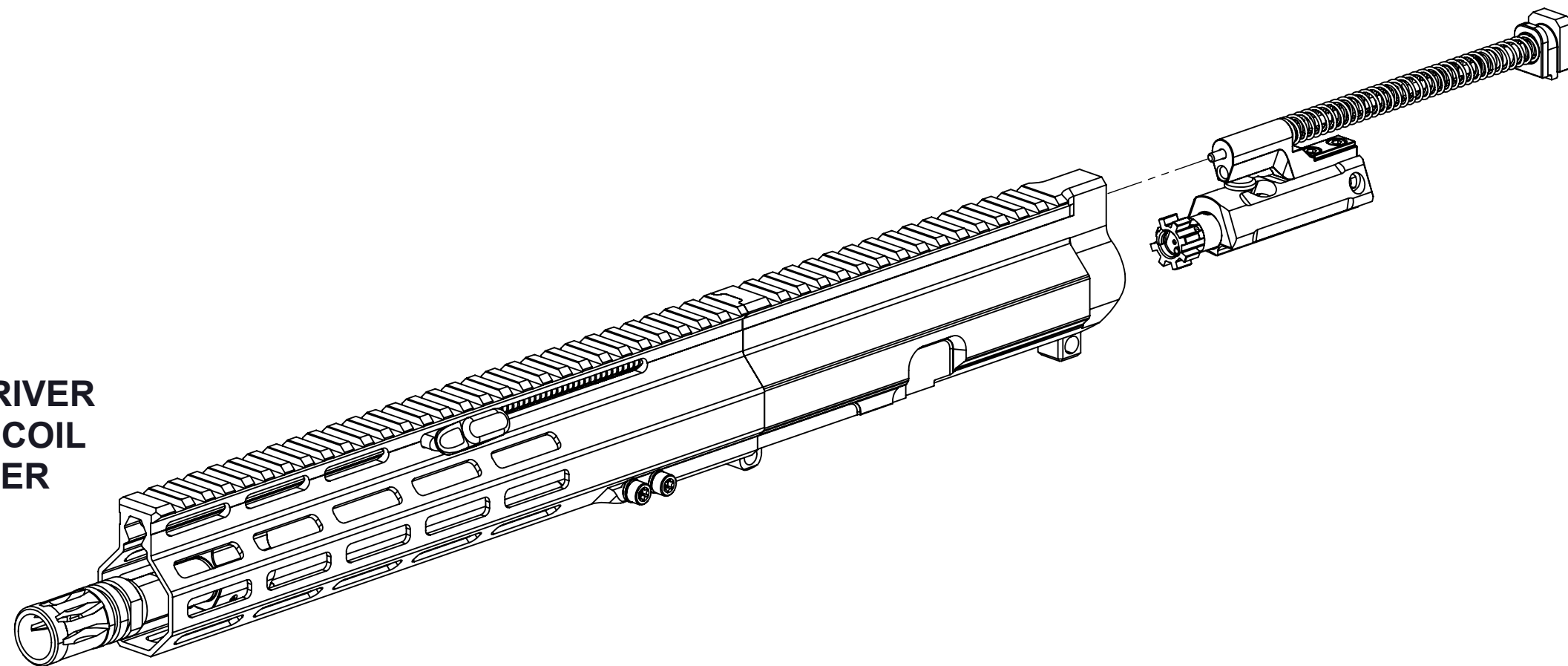

**STEP 2: USE IP27 TORX DRIVER TO REMOVE TWO HANDGUARD SCREWS & SPLIT WASHER**

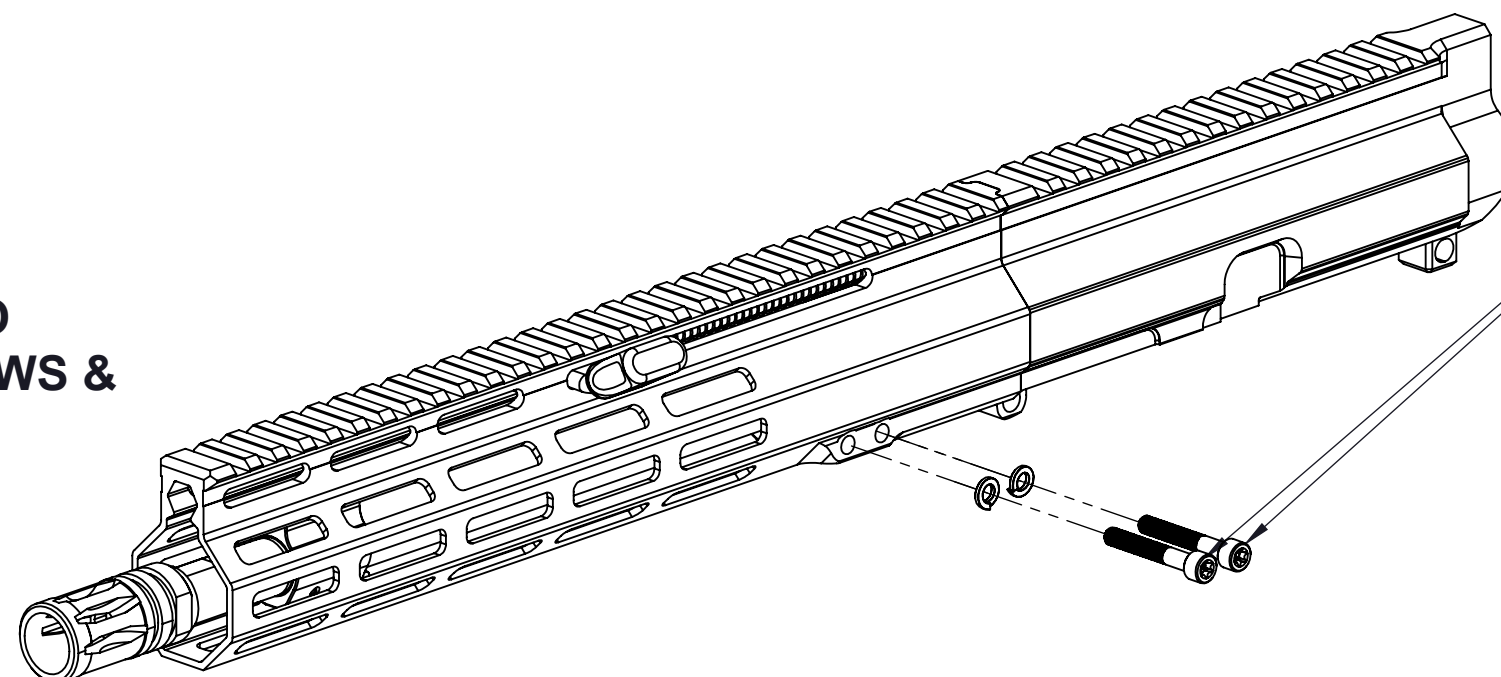

**DO NOT EXCEED 20 IN/LB DURING REASSEMBLY  
EXCESSIVE TORQUE CAN CAUSE THE THREADS IN THE HANDGUARD TO TEAR OUT AND RENDER THE HANDGUARD INOPERABLE**

**STEP 3: SLIDE HANDGUARD ASSEMBLY FORWARD OFF OF UPPER RECEIVER ASSEMBLY**

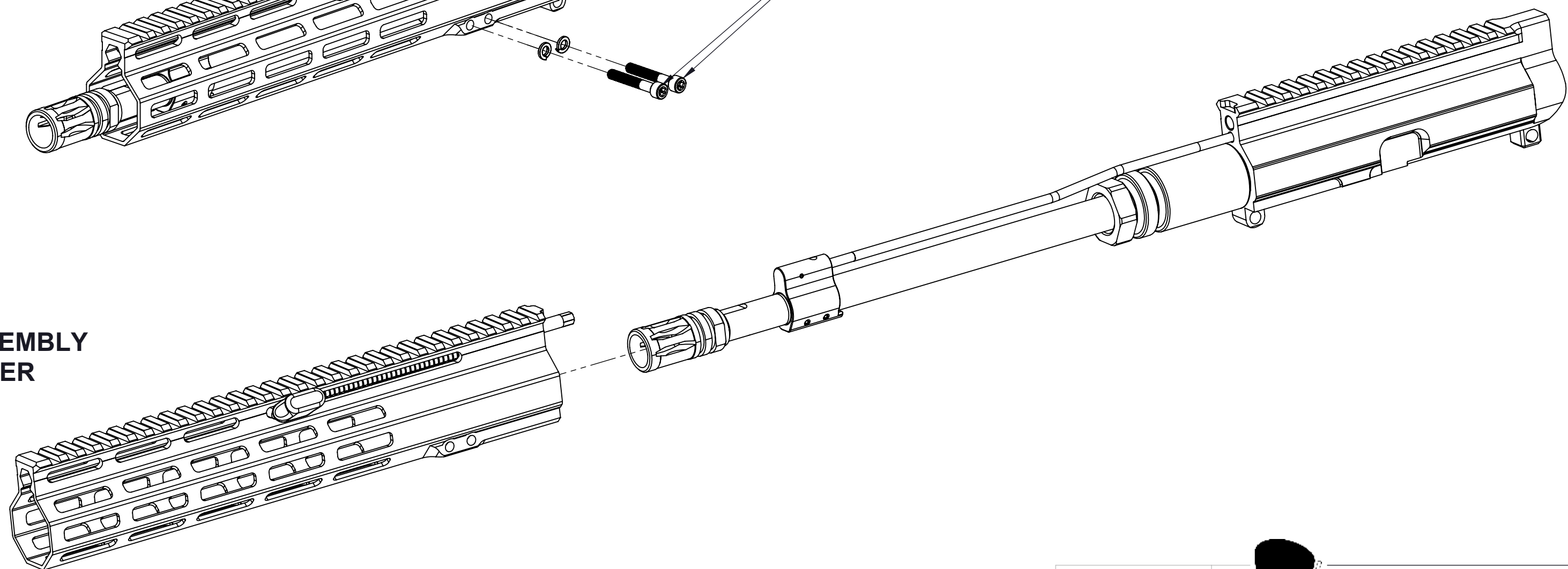

UNLESS OTHERWISE SPECIFIED DIMENSIONS ARE IN INCHES  
TOLERANCES:  
ANGULAR: ±1°  
TWO PLACE DECIMAL ±.01  
THREE PLACE DECIMAL ±.005



**FOXTROT MIKE PRODUCTS**  
QUESTIONS?  
INFO@FM-PRODUCTS.COM

PROPRIETARY & CONFIDENTIAL  
THE INFORMATION CONTAINED IN THIS DRAWING IS THE SOLE PROPERTY OF FOXTROT MIKE PRODUCTS. ANY REPRODUCTION IN PART OR AS A WHOLE WITHOUT THE WRITTEN PERMISSION OF FOXTROT MIKE PRODUCTS IS PROHIBITED.

TITLE: **REVISED GEN 2 CHARGING HANDLE DISASSEMBLY INSTRUCTIONS**

SIZE	DWG. NO.	REV
C	2308013	A

DO NOT SCALE DRAWING	SCALE: 1:2	WEIGHT:	SHEET 1 OF 2
----------------------	------------	---------	--------------

REV.	DESCRIPTION	DATE	APPROVED
A	PRELIMINARY RELEASE	9/5/23	A. TROUT

**STEP 4: USE 7/32" WRENCH TO LOOSEN CHARGING HANDLE ROD. PULL ROD AND SPRING OUT FROM REAR OF HANDGUARD.**

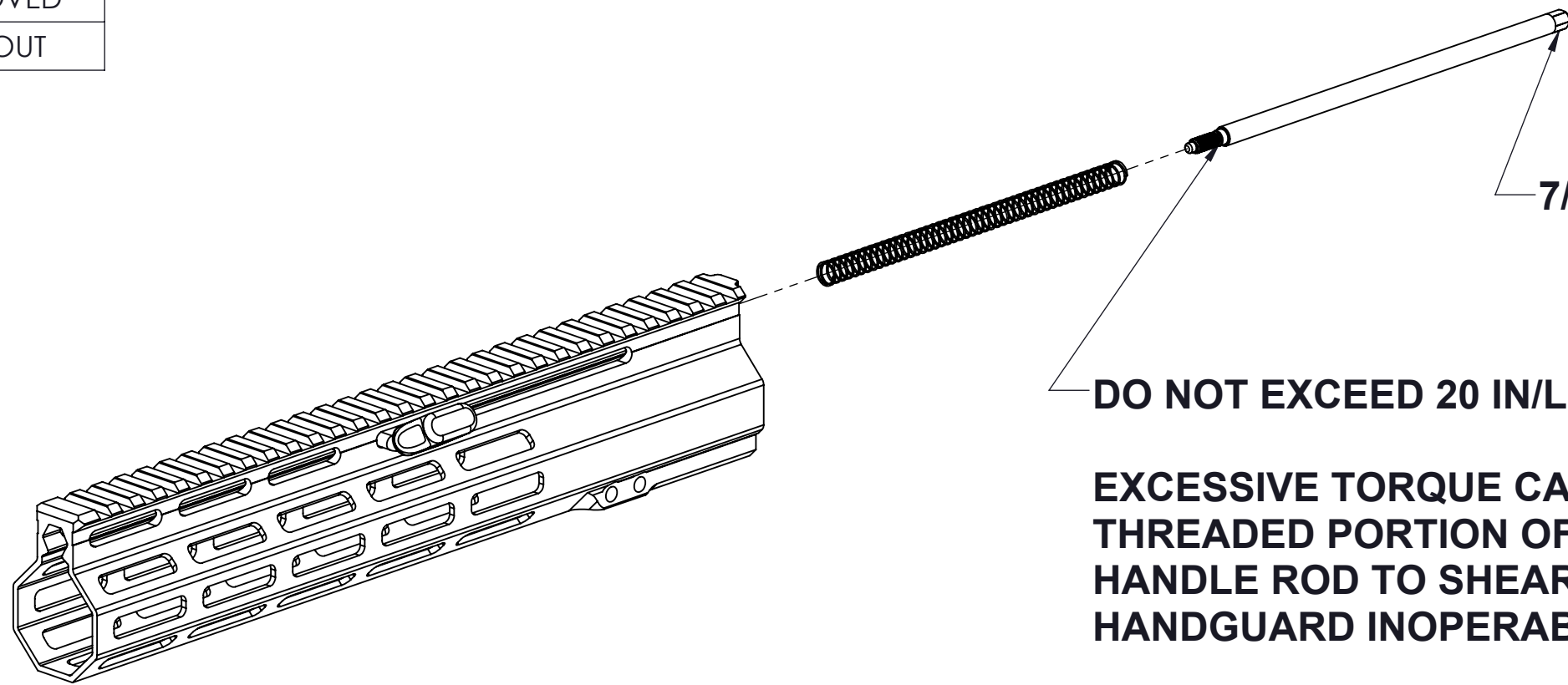

**DO NOT EXCEED 20 IN/LB DURING REASSEMBLY**

**EXCESSIVE TORQUE CAN CAUSE THE THREADED PORTION OF THE CHARGING HANDLE ROD TO SHEAR AND RENDER THE HANDGUARD INOPERABLE**

**STEP 5: USE LONG 3/32" HEX KEY TO REMOVE TWO #10-32 SET SCREWS FROM THE FRONT OF THE CHARGING HANDLE TROLLEY**

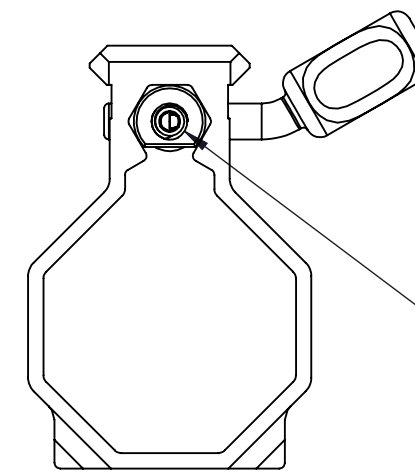
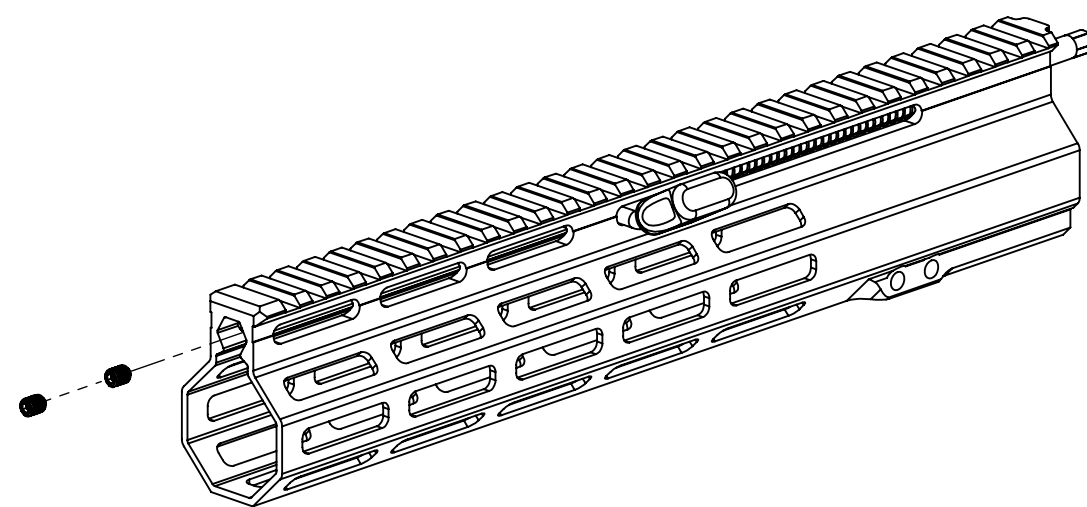

**SET SCREWS ARE LOCATED HERE IN THE FRONT OF THE CHARGING HANDLE TROLLEY**

**STEP 6: PULL OUT THE CHARGING HANDLE AND SLIDE THE CHARGING HANDLE TROLLEY OUT OF THE HANDGUARD HEX CHANNEL**

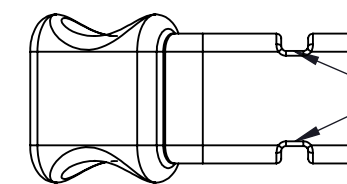
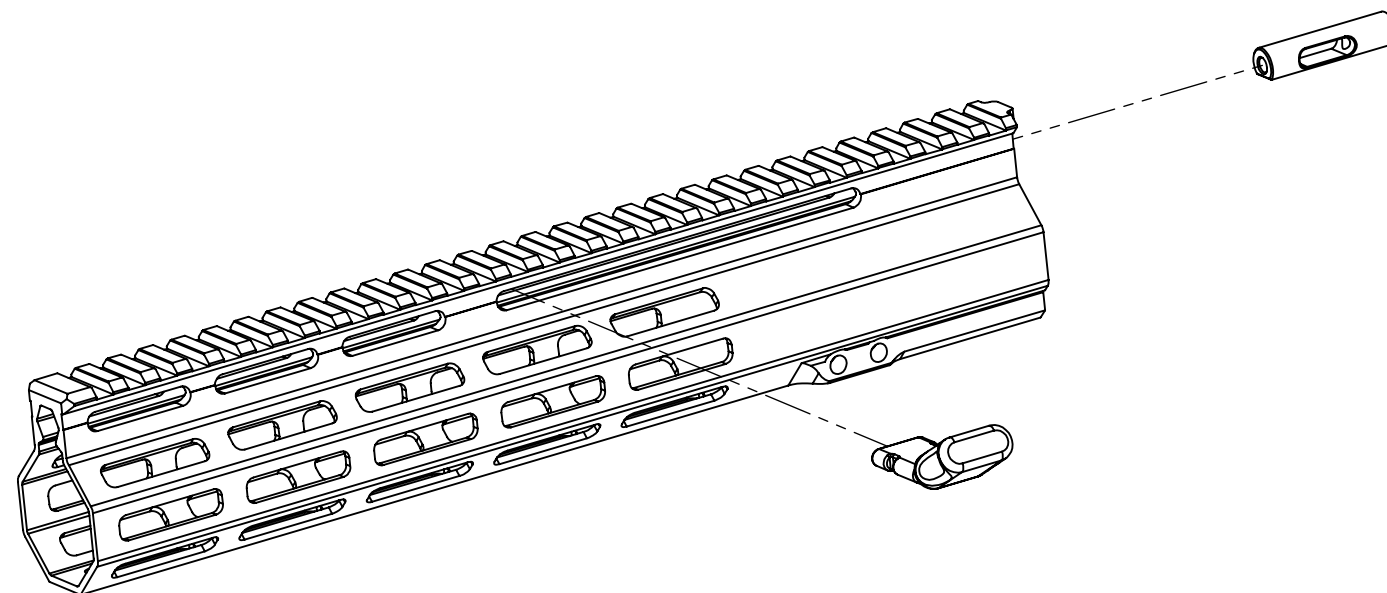

**CHARGING HANDLES MUST HAVE TWO NOTCHES SO THE CHARGING HANDLE ROD CAN PROPERLY SEAT AGAINST CHARGING HANDLE.**

**USING A CHARGING HANDLE WITH ONLY ONE NOTCH WILL CAUSE THE CHARGING HANDLE ROD TO BE TOO LONG IN THE UPPER RECEIVER AND CAUSE MALFUNCTIONS.**

**ASSEMBLY NOTES:**

- 1. REASSEMBLE IN REVERSE ORDER**
- 2. CLEAN ALL THREADS WITH ACETONE OR SIMILAR SOLVENT**
- 3. USE BLUE LOCTITE 243 OR SIMILAR THREAD LOCKER ON THREADS**
- 4. TIGHTEN ALL THREADS TO 15-20 IN/LBS**
- 5. LUBE THE EXTERIOR OF THE CHARGING HANDLE ROD & TROLLEY WITH GREASE BEFORE INSTALLING HANDGUARD ON UPPER RECEIVER ASSEMBLY**

UNLESS OTHERWISE SPECIFIED DIMENSIONS ARE IN INCHES  
 TOLERANCES:  
 ANGULAR: ±1°  
 TWO PLACE DECIMAL ±.01  
 THREE PLACE DECIMAL ±.005

PROPRIETARY & CONFIDENTIAL  
 THE INFORMATION CONTAINED IN THIS DRAWING IS THE SOLE PROPERTY OF FOXTROT MIKE PRODUCTS. ANY REPRODUCTION IN PART OR AS A WHOLE WITHOUT THE WRITTEN PERMISSION OF FOXTROT MIKE PRODUCTS IS PROHIBITED.



**FOXTROT MIKE PRODUCTS**  
 QUESTIONS?  
 INFO@FM-PRODUCTS.COM

TITLE: **REVISED GEN 2 CHARGING HANDLE DISASSEMBLY INSTRUCTIONS**

SIZE: **C** DWG. NO.: **2308013** REV: **A**

DO NOT SCALE DRAWING SCALE: 1:2 WEIGHT: SHEET 2 OF 2